

applications

Application

Light Duty

- Office/Lateral Filing
- Stationery Stores
- Magnetic Media
- Packaging Materials
- Retailing/Garment Racking

Medium Duty

- Shelving Systems
- Small Parts/Bins
- Book Libraries
- Archive Stores
- Medical Records

Heavy Duty

- Pallet Racking
- Widespan Racking
- Tool Cabinets/Drawers
- Mobiles on Mezzanine Floors
- Cantilever Racking



bespoke manufacture

Using the latest CAD-CAM technology we can design and build bespoke products to your needs

the next generation

excellence by design

concept

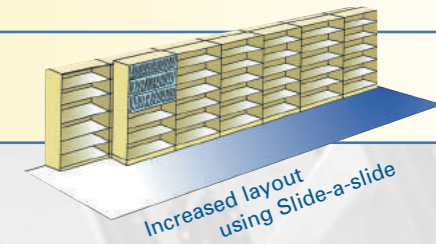
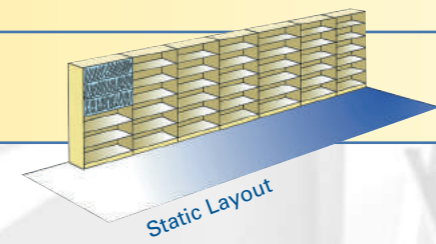
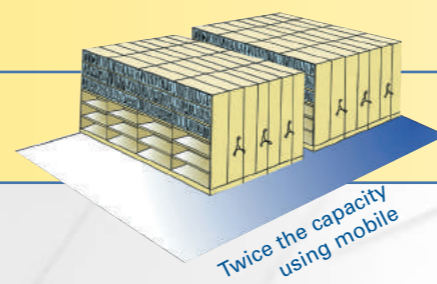
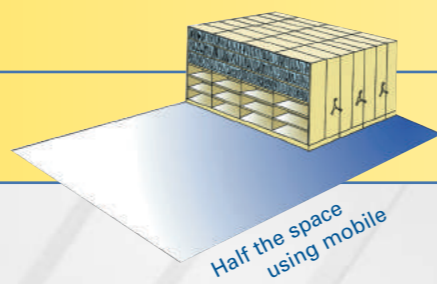
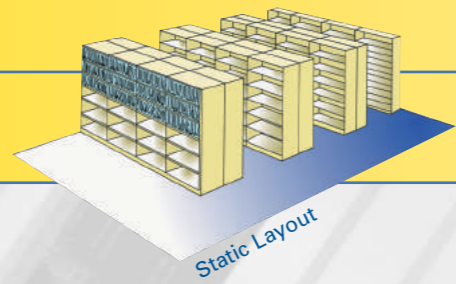

shelving



cabinets



pull out rails



tambour doors



slide a side



tape storage & narrow media



multiple applications

It's a fact of life that all types of business will outgrow their available space at some time.

Why wait for the inevitable problem to arise?

The cost of moving or extending premises can easily be avoided by investing in a "Mobile Storage System."

features

- Choice of colours
- Protection & security
- Safety anti-tip devices

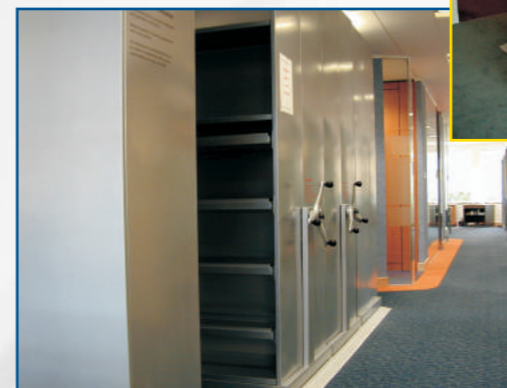
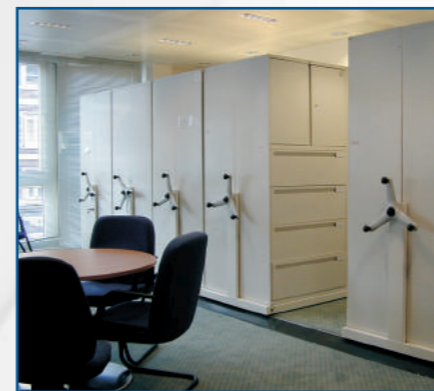

- Computer design & testing
- Technical analysis including load data
- Modular design for easy relocation, addition & alteration
- Projects designed specifically to solve your problems
- Modular free standing office systems
- Minimal noise and dust during installation
- Easy to relocate

E.L. Safety System
Simple "Push Lock" Operation



A system for every requirement

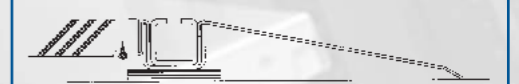

1. System R Track, with 22mm non-slip melamine floor & aluminium Ramp

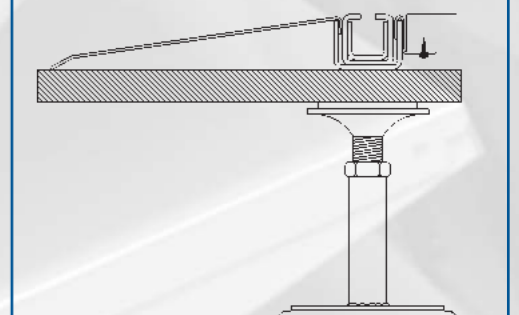

2. System R Track & jack for raised access floors

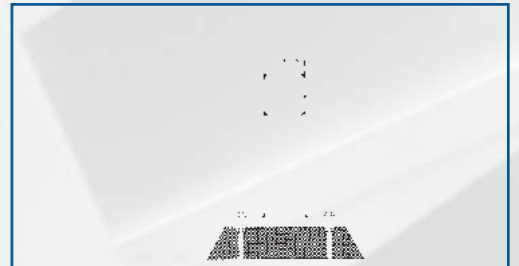

3. Track within a raised access floor